

Pro-V™ Multivariable Flowmeter

Model M22 In-line Vortex



VorTek Instruments' Pro-V™ multivariable flowmeters utilize three primary sensing elements—a vortex shedding velocity sensor, an RTD temperature sensor, and a solid-state pressure transducer—to measure the mass flow rate of gases, liquids and steam.

Systems that use external process meas-

urements to calculate mass flow may not provide adequate compensation for the fact that process conditions can change radically between the point of velocity measurement and the point where upstream or downstream pressure and temperature measurements are being made. Because the Pro-V™ multivariable flowmeter measures all of these parameters in a single location, it delivers a more accurate process measurement.

Integrating multivariable output capability with a single line penetration also simplifies system complexity and helps reduce initial equipment cost, installation cost and maintenance costs.

The product line is available with a wide range of options and meter configurations to meet your specific application requirements.

Pro-V™ Advantage:

- Volumetric or mass flow monitoring of most liquids, gases, and steam
- Multivariable meter delivers mass flow, temperature, pressure, and density readings from a single installed device and reduces initial cost, installation cost and cost-of ownership over the lifetime of the instrument
- Mass flow equations - real gas, ideal gas, AGA 8, API 2540
- Compensated mass flow reading of liquids, gases, and steam
- Energy Monitoring—ability to compute and output energy use
- Easy to install and commission
- Reliable—no moving parts, no fluid to sensor contact
- High accuracy with rangeability up to 100:1
- Temperature up to 750°F
- Pressure up to 1500 psig
- Inline configuraton for pipes from 1/2" - 8" DN15 to DN 200
- Field configurable ranges, outputs and displays
- Remote electronics option available for use in harsh environments or locations with limited access
- 4-20mA loop—powered Mass Meter design saves on energy costs
- HART protocol communications - Standard
- Modbus communications available
- FM, FMC, ATEX, IECEx Approved



VorTek
INSTRUMENTS

Engineering mesures precision
120 Route de Versailles, 91160 Champlan,
France

Tel: 01 69 41 41 41

Email: info@mesure.com

Web: www.mesure.com



Pro-V™ Principle of Operation

Vortex flowmeters measure flows of liquid, gas and steam by detecting the frequency at which vortices are alternately shed from a bluff body. According to proven laws of physics, the frequency at which the vortices are alternately shed is directly proportional to the flow velocity.

As flow passes a bluff body in the flow stream, the vortices create low and high pressure zones behind the bluff body, or shedder bar. The Pro-V™ M22 uses a piezoelectric crystal sensor to detect the pressure exerted by the vortices on the velocity sensor. The piezoelectric converts these “pulses” into electrical signals. The meter uses an all welded sensor design to create a robust sensor and to minimize potential leakages.

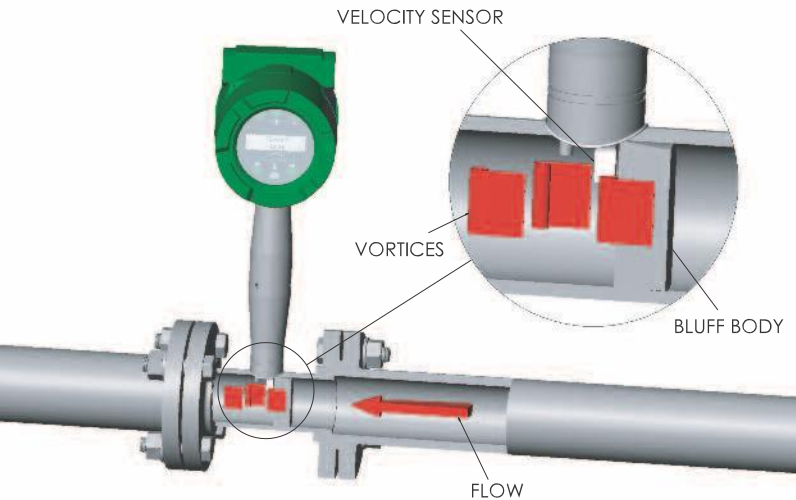

Pro-V™ Model M22-VTP

The Model M22-VTP offers you flow computer functionality in a compact field device. This multivariable instrument incorporates temperature and pressure sensors to provide an instantaneous reading of the compensated mass flow rate of gases, liquids and steam. In addition to outputs for totalized mass and alarm settings, the field-configurable electronics deliver up to three analog 4-20 mA outputs of five process measurements, including volumetric flow rate, mass flow rate, pressure, temperature and density.

Pro-V™ Model M22-VT

The Model M22-VT integrates a precision 1000 Ohm platinum RTD temperature sensor that can be used to calculate and output a compensated mass reading. This device is typically used to measure flow rates of saturated steam.

Pro-V™ Model M22-V

The Model M22-V delivers a direct reading of volumetric flow rate—generally the most cost-effective solution for liquid flow monitoring—in applications ranging from general water flows to hydrocarbon fuel flow measurement.

Pro-V™ Model M22-EM

The Model M22 Energy Monitoring option permits real-time calculation of energy consumption for a facility or process. The meter can be programmed to measure steam, hot water or chilled water. The Model M22-VTP flowmeter monitors one side of the process, either sent or returned, and uses the input from a second separate temperature sensor on the opposite leg of the process to calculate the change in energy. Selectable energy units include Btu, joules, calories, Watt-hours, Megawatt-hours and Horsepower-hours. The local or remote electronics indicate two temperatures, delta T, mass total and energy total.

Performance Specifications

Accuracy

Mass flow rate accuracy for gas and steam based on 50-100% of pressure range.

Pro-V™ Model M22 Accuracy Flowmeter		
Process Variables	Liquids	Gas & Steam
Volumetric Flow Rate	± .7% of Rate	± 1% of Rate
Mass Flow Rate	± 1% of Rate	± 1.5% of Rate
Temperature	± 2°F (± 1°C)	± 2°F (± 1°C)
Pressure	± .3% of Full Scale	± .3% of Full Scale
Density	± .3% of Reading	± .5% of Reading

Repeatability

Mass Flow Rate ± .2% of rate
 Volumetric Flow Rate ± .1% of rate
 Temperature ± .2°F (± .1°C)
 Pressure ± .05% of full scale
 Density ± .1% of reading

Stability Over 12 Months

Mass Flow Rate ± .2% of rate
 Volumetric Flow Rate ± negligible
 Temperature ± .9°F (± .5°C)
 Pressure ± .1% of full scale
 Density ± .1% of reading

Response Time

Adjustable from 1 to 100 seconds

Operating Specifications

Any gas, liquid or steam compatible with 316L stainless steel, C276 hastelloy or A105 carbon steel. Not recommended for multi-phase fluids.

Process and Ambient Temperature

Process Standard Temperature (code ST): -330 to 500°F (-200 to 260°C)
 Process High Temperature (code HT): to 750°F (400°C)
 Ambient Operating: -40 to 140°F (-40 to 60°C)
 Ambient Storage: -40 to 185°F (-40 to 85°C)

Pressure Transducer Ratings			
Full Scale Operating Pressure		Max. Over-Range Pressure	
psia	bara	psia	bara
30	2	60	4
100	7	200	14
300	20	600	40
500	35	1000	70
1500	100	2500	175

Power Requirements

12 to 36 VDC, 25 mA, 1 W max., Loop Powered Volumetric or Mass
 12 to 36 VDC, 300 mA, 9 W max. Multiparameter Mass options
 100 to 240 VAC, 50/60 Hz, 5W max. Multiparameter Mass options

Display

Alphanumeric 2 line x 16 character LCD digital display
 Six pushbuttons for full field configuration
 Pushbuttons can be operated with magnetic wand without removal of enclosure covers
 Display can be mounted in 90° intervals for better viewing

Output Signals

Analog: 4-20 mA
 Alarm: Solid state relay, 40 VDC
 Totalizer Pulse: 50 millisecond pulse, 40 VDC
 Volumetric or Loop Powered Mass: One analog, one totalizer pulse, HART
 Multivariable option: Up to three analog signals, three alarms, one totalizer pulse, HART
 Multivariable option: Modbus process monitoring

Physical Specifications

Wetted Materials

Standard 316L Stainless Steel, plus
 • Optional Carbon Steel or Hastelloy C

- DuPont Teflon® based thread sealant on models with pressure transducer

Approvals

FM, FMC CLASS I, DIV. 1, GROUPS B,C,D
 CLASS II/III, DIV. 1, GROUPS E,F,G
 Type 4X and IP66, T6 Ta = -40 to 70°C

ATEX II 2 G Ex d IIB + H2 T6
 II 2 D EX tD A21 IP66 T85°C

IECEX Ex d IIB + H2 T6
 Ex tD A21 IP66 T85°C

Sizing Considerations

Piping Conditions

Condition	Pipe Diameters, D	
	Upstream	Downstream
One 90° elbow before meter	10D	5D
Two 90° elbows before meter	15D	5D
Two 90° elbows before meter, out of plane	25D	5D
Reduction before meter	10D	5D
Expansion before meter	20D	5D
Partially open valve	25D	5D

Velocity Range

Maximum velocity, liquid: 30 feet/sec (9 meters/second)

Minimum velocity, liquid: 1 foot/sec (.3 meters/second)

Maximum velocity, gas or steam: 300 feet/sec (90 meters/second)

Minimum velocity, gas or steam feet/sec (meters/second):

$$\frac{5}{\sqrt{\text{density (Lb/ft}^3)}} \quad \frac{6.1}{\sqrt{\text{density (kg/m}^3)}}$$

Consult the VorTek Instruments Sizing Program @vortekinst.com for easy calculation of flow range.

Water Minimum and Maximum Flow Rates

Rate	Nominal Pipe Size (in)								
	0.5	0.75	1	1.5	2	3	4	6	8
GPM min	0.9	1.4	2.2	5.5	9.2	21	36	81	142
GPM max	22	40	67	166	276	618	1076	2437	4270
	Nominal Pipe Size (mm)								
	15	20	25	40	50	80	100	150	200
M ³ /hr min	0.2	0.3	0.5	1.3	2.1	4.7	8.1	18	32
M ³ /hr Max	5	9	15	38	63	140	244	554	970

Typical Saturated Steam Minimum and Maximum Flow Rates (lb/hr)									
Nominal Pipe Size (in)									
Pressure	0.5	0.75	1	1.5	2	3	4	6	8
5 psig	6.5	12	20	49	82	183	318	722	1264
	52	122	265	650	1087	2431	4231	9594	16806
100 psig	15	27	46	112	187	419	728	1652	2893
	271	639	1386	3405	5690	12729	22156	50233	87998
200 psig	20	37	62	151	253	565	983	2229	3905
	493	1163	2525	6203	10365	23184	40354	91494	160279
300 psig	24	45	74	182	304	680	1184	2685	4704
	716	1688	3664	9000	15040	33642	58556	132763	232575
400 psig	28	51	85	209	349	780	1358	3079	5393
	941	2220	4816	11831	19770	44222	76971	174516	305717
500 psig	31	57	95	233	389	870	1514	3433	6014
	1170	2760	5988	14711	24582	54987	95710	217001	380148

Typical Saturated Steam Minimum and Maximum Flow Rates (kg/hr)									
Nominal Pipe Size (mm)									
Pressure	15	20	25	40	50	80	100	150	200
0 barg	3	5	8	19	32	72	126	286	500
	18	42	91	224	375	838	1459	3309	5797
5 barg	6	11	18	45	75	167	290	658	1153
	95	224	485	1192	1992	4455	7754	17581	30799
10 barg	8	15	24	59	99	222	387	877	1537
	168	397	862	2118	3539	7915	13777	31237	54720
15 barg	9	17	29	71	119	266	463	1050	1840
	241	569	1236	3036	5073	11347	19750	44779	78444
20 barg	11	20	33	81	136	304	529	1199	2100
	314	742	1610	3956	6611	14787	25738	58355	102226
30 barg	13	24	40	99	165	369	642	1455	2548
	463	1092	2370	5822	9729	21763	37880	85884	150451

Typical Air Minimum and Maximum Flow Rates (SCFM)									
Air at 70°F									
Nominal Pipe Size (in)									
Pressure	0.5	0.75	1	1.5	2	3	4	6	8
0 psig	1.8	3	5	13	22	50	87	198	347
	18	41	90	221	369	826	1437	3258	5708
100 psig	5	9	15	38	63	141	245	555	972
	138	325	704	1730	2890	6466	11254	25515	44698
200 psig	7	13	21	52	86	193	335	761	1332
	258	609	1322	3248	5427	12140	21131	47911	83931
300 psig	8	15	25	63	104	234	407	922	1615
	380	896	1944	4775	7978	17847	31064	70431	123375
400 psig	10	18	29	72	120	269	467	1060	1857
	502	1183	2568	6309	10542	23580	41043	93057	163000
500 psig	11	20	33	80	134	300	521	1182	2071
	624	1472	3195	7849	13115	28034	51063	115775	203000

Typical Air Minimum and Maximum Flow Rates (nm ³ /hr)									
Air at 20°C									
Nominal Pipe Size (mm)									
Pressure	15	20	25	40	50	80	100	150	200
0 barg	3	5	9	21	36	79	138	313	549
	28	66	142	350	584	1307	2275	5157	9034
5 barg	7	13	21	52	87	194	337	764	1339
	165	390	847	2080	3476	7775	13533	30682	53749
10 barg	9	17	29	70	117	262	457	1035	1814
	304	716	1554	3819	6381	14273	24844	56329	98676
15 barg	11	21	34	85	142	317	551	1250	2190
	442	1044	2265	5565	9299	20801	36205	82087	143801
20 barg	13	24	40	97	162	363	632	1434	2511
	582	1373	2979	7318	12229	27354	47612	107949	189105
30 barg	16	29	48	118	198	442	770	1745	3057
	862	2034	4414	10843	18119	40529	70544	159942	280187

Turndown

Turndown is application dependent. Consult the VorTek Instruments Sizing Program @vortekinst.com for exact values.

Turndown can exceed 100:1

Dimensional Outline: Pro-V™ Inline Flanged Models

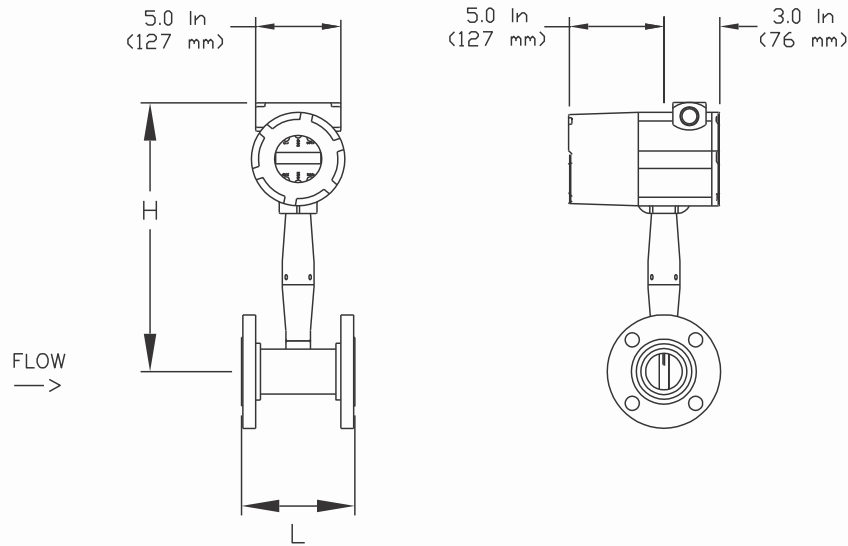

Flow Meter Nominal Size	L	H	WEIGHT		
			ANSI 150 (PN 16)	ANSI 300 (PN 40)	ANSI 600 (PN 64)
1/2 inch (15mm)	4.56 in (116 mm)	14.8 in (376 mm)	12 Lb (5.5 Kg)	12.5 Lb (5.7 Kg)	13 Lb (5.9 Kg)
3/4 inch (20mm)	4.8 in (122 mm)	15 in (381 mm)	13 Lb (5.9 Kg)	14 Lb (6.4 Kg)	14.5 Lb (6.6 Kg)
1 inch (25mm)	4.94 in (126 mm)	15 in (381 mm)	13.4 Lb (6.1 Kg)	16.3 Lb (7.4 Kg)	16.3 Lb (7.4 Kg)
1-1/2 inch (40mm)	5.5 in (140 mm)	15 in (384 mm)	14.5 Lb (6.6 Kg)	22.7 Lb (10.3 Kg)	24.6 Lb (11.2 Kg)
2 inch (50mm)	6.0 in (153 mm)	15.3 in (389 mm)	19.4 Lb (8.8 Kg)	26.8 Lb (12.2 Kg)	33.2 Lb (15.1 Kg)
3 inch (80mm)	6.9 in (175 mm)	15.8 in (401 mm)	27.5 Lb (12.5 Kg)	39.4 Lb (17.9 Kg)	56.1 Lb (25.5 Kg)
4 inch (100mm)	8.0 in (203 mm)	16.2 in (411 mm)	43.3 Lb (19.7 Kg)	60.3 Lb (27.4 Kg)	96 Lb (43.6 Kg)
6 inch (150mm)	9 in (229 mm)	17.3 in (439 mm)	48.4 Lb (22.0 Kg)	96 Lb (43.6 Kg)	178 Lb (80.8 Kg)
8 inch (200mm)	10.5 in (267 mm)	18.2 in (462 mm)	71 Lb (32.2 Kg)	148 Lb (67.4 Kg)	299 Lb (136 Kg)

Add 11 Lb (5 KG) for remote electronics

Dimensional Outline: Pro-V™ Inline Wafer Models

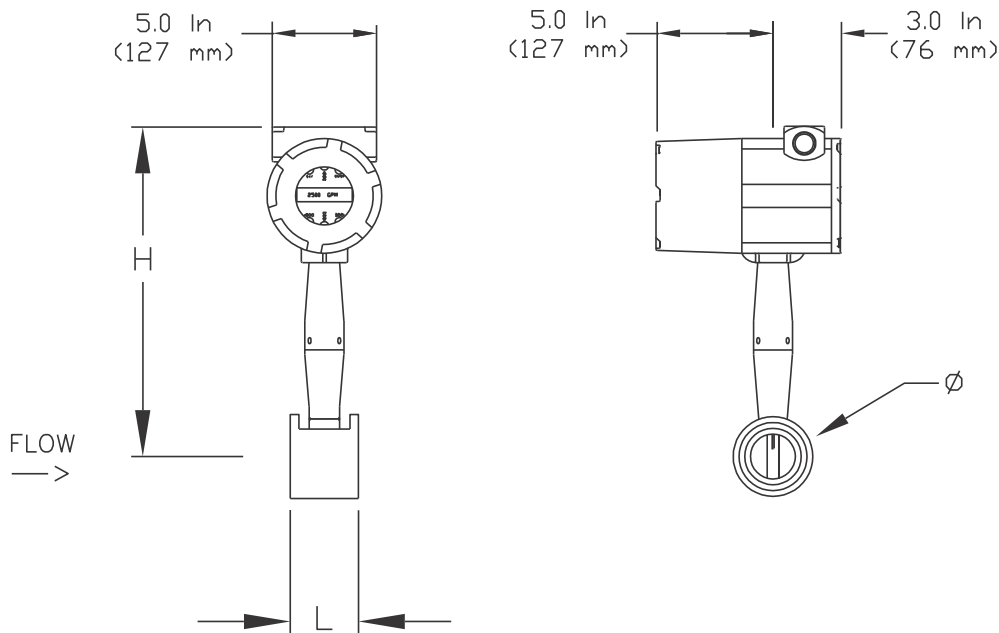

Flow Meter Nominal Size	L	H	Ø	WEIGHT
1/2 inch (15mm)	4.56 in (116 mm)	14.8 in (376 mm)	1.38 in (35 mm)	9.8 Lb (4.4 Kg)
3/4 inch (20mm)	4.8 in (122 mm)	15 in (381 mm)	1.69 in (43 mm)	10 Lb (4.5 Kg)
1 inch (25mm)	2.8 in (71 mm)	14.8 in (376 mm)	2.00 in (51 mm)	10.1 Lb (4.6 Kg)
1-1/2 inch (40mm)	2.8 in (71 mm)	15.1 in (384 mm)	2.88 in (73 mm)	11.9 Lb (5.4 Kg)
2 inch (50mm)	3.0 in (76 mm)	15.3 in (389 mm)	3.62 in (92 mm)	14.1 Lb (6.4 Kg)
3 inch (80mm)	4 in (102 mm)	15.8 in (401 mm)	5 in (127 mm)	22.7 Lb (10.3 Kg)
4 inch (100mm)	4.7 in (119 mm)	16.2 in (411 mm)	6.19 in (157 mm)	33 Lb (15.0 Kg)

Add 1 Lb (5 KG) for remote electronics

Dimensional Outline: Remote Electronics Option

