

FCI ST80 Series Thermal Mass Flow Meters

Advanced Solutions for Process and Plant
Gas Flow Metering

Mass Flow and Temperature

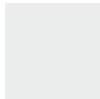
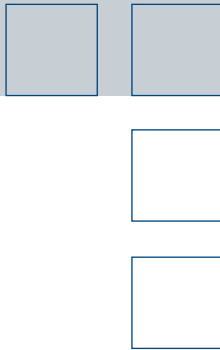

For Air and Gas Flow Applications in:

- Chemical
- Wastewater Treatment
- Refineries
- Oil and Gas
- Mining
- Metals
- Manufacturing
- Cement, Stone, Brick, Glass
- Power Utilities
- Landfills
- Pulp and Paper
- Water Treatment
- Food and Beverage
- And more...

FCI ST80 SERIES

FCI FLUID COMPONENTS
INTERNATIONAL LLC

A PST BRAND

ST80 Series Features

- Direct air and gas mass flow measuring
- Flow rate, total flow, and temperature
- No moving parts, lowest maintenance
- Pipe diameters 1" to 99" [25 mm to 2500 mm]
- Extensive and comprehensive global approvals for Ex installations
- Temperature service to 850 °F [454 °C]
- Rugged, industrial transmitter enclosure
- Graphic, multivariable LCD readout
- SIL compliance
- Integral and remote electronics versions
- Dual 4-20 mA analog outputs
- HART®, FOUNDATION™ Fieldbus, PROFIBUS PA and DP, Modbus RS-485
- 3-point in-situ calibration self-test
- Sensor configurations to optimize application performance, including new wet gas element
- Extensive selection of process connections



Model ST80 (left) is an insertion flow meter for pipe sizes from 2 1/2" to 99" [64 mm to 2500 mm]. Typical calibration range is from 0.25 SFPS to 1000 SFPS [0.07 NMPS to 305 NMPS].

Model ST80L (right) is an in-line flow meter for use in line sizes 1", 1 1/2" and 2" [DN25, DN40, and DN50]. Typical calibration range is from 0.006 SCFM to 838 SCFM [0.01 NCMH to 1425 NCMH].

The ST80 Air / Gas Mass Flow Meter Solution

ST80 flow meters combine proprietary equal mass thermal dispersion flow sensing elements, precision electronics, and exacting fluid calibrations, all packaged within rugged, industrial enclosures. The ST80 Series delivers a superior air/gas flow measurement solution that continuously meets performance specifications in the most demanding process and plant applications with virtually no scheduled maintenance.

ST80 flow meters feature FCI's patented no moving parts flow element designs that provide direct mass flow measurement with just a single process penetration. This saves you space and

eliminates unnecessary installation, expense, and performance degradation associated with separate temperature and pressure sensors, and density calculation devices needed with inferred mass flow techniques. With no moving parts to plug or foul, ST80s deliver extensive cost savings over alternative high maintenance technologies. The result is an accurate and highly repeatable mass flow measurement at the lowest total installed cost. In today's complex process control schemes, the ST80 Series provides accurate gas flow measurements essential for process consistency, quality and safe plant operation.

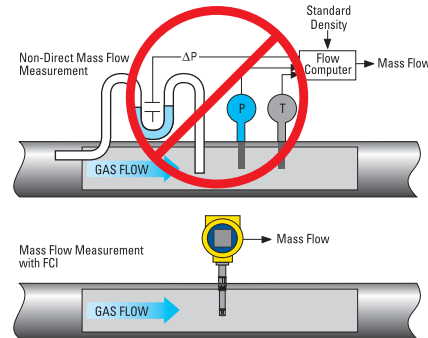

FCI's ST80 Series features an accuracy of $\pm 1\%$ of reading, 0.5% of full scale and repeatability of $\pm 0.5\%$ of reading. The turndown ratio is factory preset to your application from a minimum of 2:1 to a maximum of 100:1 and is field adjustable within the calibrated range. ST80 flow meters are offered in a wide range of packaging options, mounting and installation options that ensure configuration matched to your exact application conditions. From compressed air to hydrocarbon gases, single gases to biogas mixtures, ST80 flow meters are at work improving processes throughout the world.

Dual-Technology Measuring Ensures Field Performance and Application Adaptability

FCI's ST80 is the only thermal dispersion flow meter to deploy both constant power (CP) and constant temperature (CT) thermal dispersion measuring techniques in the same instrument. For many applications the ST80 will be factory set in FCI's patented AST™ (Adaptive Sensing Technology) mode. AST™ is a hybrid that combines both CT and CP techniques in the same circuit. In AST™ operation the instrument measures in CT mode when in lower flow ranges or start-up conditions, and will transparently and seamlessly shift to CP mode at higher flow rates. The result is a best-of-both technology, achieving fast response, extended measuring range, and low power consumption. For other applications such as moist gases, pulsating flow streams and others where a smoother, stable output is critical, the ST80 can also be set to measure in only CP mode. Since application conditions are not always completely known or understood at time of order, the ST80's measuring mode can be user changed between AST™ or fixed CP in the field to adapt to actual application conditions.

Sensors Optimized to Meet the Application



"FPC" Style Element



"FP" Style Element



"S" Style Element



"WG" Style Wet Gas Element

High quality thermal mass flow measurement begins with the sensor element in the flow stream. Only FCI combines six decades of field experience with extensive R&D and performance validation utilizing an on-premise flow laboratory with more than 19 flow stands. FCI is the leader in thermal mass flow sensor innovation, reducing the size of instruments, accelerating response time and improving overall operation in applications with dramatic temperature swings. Further, ST80 Series flow elements are all-welded to ensure maximum strength, durability and leak prevention, and are offered standard in either 316L stainless steel or Hastelloy-C276.

The "WG" is a new, FCI exclusive design specifically for use in wet gas or rain-down applications. This truly unique, mechanical design shunts moisture, condensation and water droplets away from the sensors, allowing the sensors to accurately measure the gas flow without being disrupted by water hitting the sensors. This "WG" sensor can be ordered for use with entrained moisture (moisture flow is same direction with gas) or for rain (incoming moisture in opposite direction from gas flow).

The table below provides a summary of conditions and characteristics to consider in selecting a flow element style.

ST80 Series Flow Element Selection

Flow Element	-FPC	-FP	-S	-WG
Available with insertion type (ST80)	✓	✓	✓	✓
Available with in-line type (ST80L)		✓*	✓	
Conditions or Characteristics				
All clean gases	■	□	□	⊘
Air / compressed air	■	□	□	⊘
Slightly dirty gases	□	■	□	⊘
Damp / moist gases	□	□	■	■
Very dirty gases	⊘	□	■	⊘
Wet gases	⊘	⊘	⊘	■
Open vertical stack or pipe with gas flow coming up, rain/moisture coming down	⊘	⊘	⊘	■
Erosive	⊘	⊘	■	⊘
Corrosive	⊘	⊘	■	⊘
Particulates in flow stream	⊘	□	■	⊘
Pulsing	■	⊘	■	⊘
Fastest response time	■	■	□	⊘
Dynamic temperature swings	■	■	⊘	⊘
Rapid or erratic changes in flow requiring smoothed response and output	⊘	⊘	■	⊘
Less-than-ideal straight run (without Vortab® flow conditioning)	■	⊘	⊘	⊘
Frequent cleaning required	⊘	□	■	⊘

■ = Excellent performance, preferred solution

□ = Good performance, acceptable solution

⊘ = Not recommended

* = Unshrouded as sensor head protected by spool-piece

Find your gas here?

FCI has provided thermal mass flow meter solutions for all of these and more . . .

Acetaldehyde	Ethyl Acrylate	Ketene	Phenol
Acetic Acid	Ethyl Alcohol	Krypton	Phosgene
Acetone	Ethyl Amine	Landfill Gas	Propadiene
Acetonitrile	Ethyl Benzene	M-Cresol	Propane
Acetyl Chloride	Ethyl Bromide	Mercury	Propanol
Air	Ethyl Chloride	Methane	Propyl Chloride
Allyl Chloride	Ethyl Fluoride	Methanol	Propylene
Ammonia	Ethyl Mercaptan	Methyl Acetate	Propylene Oxide
Aniline	Ethylene	Methyl Alcohol	Propyne
Argon	Ethylene Dichloride	Methyl Amine	P-Xylene
Benzene	Ethylene Oxide	Methyl Butane	R-11
Bio-Gas	Flare Gas	Methyl Fluoride	R-12
Boron Trifluoride	Fluorine	Methyl Formate	R-13
Bromine	Fluorobenzene	Methyl Hexane	R-13B1
Bromobenzene	Fluoroform	Methyl Hydrazine	R-14
Butadiene	Freon-11	Methyl	R-21
Butene	Freon-12	Mercaptan	R-22
Butylene Oxide	Freon-13	Methyl Octane	R-23
Butyne	Freon-14	Methyl Pentane	R-112
Carbon Dioxide	Freon-21	Methylal	R-113
Carbon Disulfide	Freon-22	Methylene Chloride	R-114
Carbon Monoxide	Freon-23	Morpholine	R-114B2
Carbon Tetrachloride	Furan	M-Xylene	R-115
Carbonyl Sulfide	Halon	Naphthalene	R-116
Chlorine	Helium	Natural Gas	R-134A
Chlorobenzene	Heptene	N-Butane	R-142B
Chloroethane	Hexanol	N-Butane	R-152A
Chloroform	Hydrazine	N-Butanol	R-216
Chloromethane	Hydrogen	N-Butyl Alcohol	R-500
Chloroprene	Hydrogen Bromide	N-Decane	R-502
Cis-2-Butene	Hydrogen Chloride	N-Dodecane	R-503
Cis-2-Hexene	Hydrogen Cyanide	Neon	R-504
Compressed Air	Hydrogen Deuteride	Neopentane	R-C318
Cumene	Hydrogen Fluoride	N-Heptane	Radon
Cyanogen	Hydrogen Iodide	N-Hexane	Silane
Cyclobutane	Hydrogen Peroxide	Nitric Oxide	Silicon Tetrachloride
Cyclohexane	Hydrogen Sulfide	Nitrogen	Styrene
Cyclooctane	Iodine	Nitrogen Dioxide	Sulfur Dioxide
Cyclopentane	Isobutane	Nitromethane	Sulfur Hexafluoride
Cyclopropane	Isobutene	Nitrous Oxide	Sulfur Trioxide
Decene	Isobutyl Alcohol	N-Nonane	Superheated Thiophene
Deuterium	Isobutyl Alcohol	N-Octane	Titanium Tetrachloride
Deuterium Oxide	Isoheptane	Nonene	Toluene
Diethyl Amine	Isohexane	N-Pentane	Trans-2-Butene
Diethyl Ether	Isooctane	N-Propanol	Trimethyl Amine
Diethyl Ketone	Isopentane	N-Propyl Alcohol	Triptane
Digester Gas	Isoprene	N-Propyl Amine	Uranium Hexafluoride
Dimethyl Ether	Isopropyl Alcohol	N-Undecane	Vinyl Acetate
Dimethyl Propane	Isopropyl Amine	Octene	Vinyl Chloride
Dimethyl Sulfide	Isopropyl Amine	Oxygen	Vinyl Fluoride
Ethane	Isopropyl Amine	O-Xylene	Vinyl Formate
Ethanol	Isopropyl Amine	Pentanol	
Ethyl Acetate	Isopropyl Amine	Pentene	

Extensive Selection of Process Connections

An unmatched selection of process connection choices assures a match for any installation requirements.

Insertion flow meter (Model ST80) – For most applications an adjustable “U” length (insertion depth) configured with compression fittings offers the most installation flexibility. Adjustable elements are available in 6 inch [152 mm], 12 inch [305 mm], 21 inch [533 mm], 36 inch [914 mm], and 60 inch [1524 mm] lengths. All adjustable “U” elements include permanent, laser-etched depth gauge markings, in both inches and millimeters, to ensure accurate insertion depth within the installation. Male NPT compression fittings are available in either 3/4 inch or 1 inch, with Teflon or metal ferrules, or with a tapped and threaded ANSI or DIN flange. Fixed length elements made to your specifications with a fixed threaded fitting or a welded ANSI or DIN flange are also available for all ST80 Series models.

For hot tap installations, retractable packing glands with a choice of pressure rating and packing material are available for all ST80 insertion flow meter models. Pressure service ratings of either 50 psi [3,4 bar] or 500 psi [34 bar] are standard with higher ratings available on special request. To ensure compatibility with the process fluid and integrity of the installation, packing material is selectable as either graphite or Teflon.

Process Connections	
Compression Fittings with variable “U” length	
3/4" MNPT	✓
1" MNPT	✓
Flange, Tapped and Threaded for 3/4" NPT Compression Fitting	✓
Retractable Packing Glands with variable “U” length	
Low Pressure ≤ 50 psi [3,4 bar(g)]	✓
Medium Pressure ≤ 500 psi [34 bar(g)]	✓
Fixed* specify “U” length up to 60" [1524mm] maximum	
1" MNPT	✓
Flanged	✓

* Not available with wet gas type flow element

In-line flow meter (Model ST80L) – The spool-piece flow body length is nine times its nominal diameter, and can be fabricated as required with male NPT, female NPT, ANSI flange, DIN flange, or butt weld prepared process connections.

Process Connections	NPT Male	NPT Female	Flanged ANSI	Flanged DIN	Butt Weld Prepared
Flow Body Type					
1" Tubing	✓	✓	✓	✓	✓
1" Pipe	✓	✓	✓	✓	✓
1 1/2" Pipe	✓	✓	✓	✓	✓
2" Pipe	✓	✓	✓	✓	✓



Adjustable “U” Length with Compression Fitting



Tapped and threaded ANSI or DIN Flange

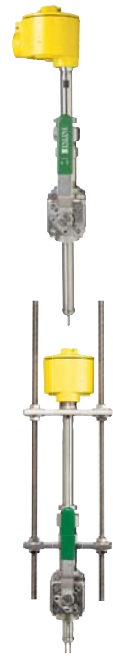

Low Pressure Packing Gland with Ball Valve (top) and Medium Pressure Packing Gland with Ball Valve (right)

Exceptional Electronics: Robust, Comprehensive, and Adaptable

The ST80's rugged, isolated and noise immune electronics design provides a selection of powering, analog outputs, digital I/O and HMI that will ensure compatibility and seamless integration with your DCS, PLC, SCADA or other measuring or control systems, today and tomorrow.

Powering

The ST80 can be ordered for either 24 Vdc or AC input powering. The 24 Vdc is a fully isolated DC supply that operates over a wide 19.2 V to 28.8 V range. The AC powered unit will operate from 85 V to 265 Vac to ensure universal operation throughout the world. As with all FCI thermal flow meters, ST80 requires less than 10 watts maximum power, which is typically half that of other thermal flow meters, resulting in significant energy cost savings over the life of the installation.

Outputs

The ST80 features multiple outputs to interface with control systems and/or set-up for configuration devices. Standard are dual 4-20mA analog outputs, HART^{1,2}, and Modbus¹. Optionally you can also add FOUNDATION Fieldbus^{1,2}, PROFIBUS PA, or PROFIBUS DP¹. The digital bus communications are full two-way I/O. The HART bus complies with version 7 protocol and is fully compatible with all versions of HART field communicators and control systems. The 4-20mA outputs are isolated and meet NAMUR NE43 guidelines for fault indication.

For digital bus communications the device drivers (DD files) for HART, FOUNDATION Fieldbus and PROFIBUS are always provided. Where FCI has created an EDD, DTM or PDM type interfaces, they will also be provided. FCI is a registered member of FieldComm Group.

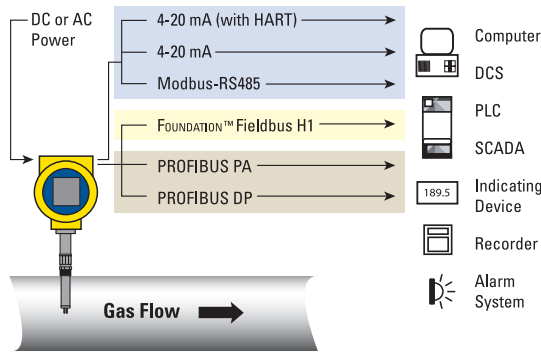

ST80 Series flow meters, with HART and FOUNDATION Fieldbus and associated DD files, are submitted to FieldComm Group for certification and registration. Please check FCI's and/or FieldComm Group's website for current status².



www.fieldcommgroup.org

www.profibus.com

www.fieldcommgroup.org

www.fdtgroup.org

The ST80 also provides a USB port to connect to a computer to do field configuration steps, changes and field diagnostics. To facilitate connection and communicate between the ST80 and your computer, FCI's "configurator" software utility tool is always provided at no additional cost.

All updates and new software are readily available and downloadable from FCI's website. Device drivers for HART and FOUNDATION Fieldbus are also available for download via FieldComm Group's website.

¹ Only one can be active at a time.

² Certification of ST80 with FOUNDATION™ Fieldbus is pending with FieldComm Group™. Manufacturer ID (HEX) 01FC49.

ST80 with HART® is certified by FieldComm Group. Registration number L2-06-1000-168; Manufacturer ID (HEX) 00A6; Device ID A677.

ST80 with PROFIBUS DP is certified by PROFIBUS.

Up to Two Unique Calibrations

While a single calibration is sufficient for many operations, the ST80 can optionally provide two (2) unique calibration groups. Depending on your application need, this feature can provide significant cost and time savings. Some examples include:

Different mixtures of same gases – Embed calibrations to optimize flow measurement accuracy in dynamic or seasonally affected processes (e.g. Digester Gas Group 1 is 65% CH₄, 35% CO₂; Group 2 is 62% CH₄, 38% CO₂).

Different gases – Portable or temporary installations for multiple applications, or to reduce spare parts inventory in plants with multiple installations and applications. Multiple gases, such as dual fuel sources (e.g. natural gas and propane).

For more than two (2) calibrations, see FCI ST100 Series, which has up to five (5).

ST80 Series In-Situ Calibration Validation Self-Test

- Simple to initiate, one minute test
- 3-point check across span
- No need to retract or remove meter from the process
- Pre-set to run automatically
- View and record results

A calibration self-test feature is standard with all ST80 Series flow meters. To save user time and expense, the self-test is performed in-situ – there is never a need for the ST80 to be removed or retracted from process piping or to suspend the processes operation.

This self-test feature initiates an electronic, three point calibration drift self-test. In the test mode, the ST80 automatically and sequentially substitutes three precision resistors into the measuring circuit and compares the resulting measurements against the same measurements at factory calibration. These three points represent low-range, mid-range and high-range points to provide a thorough check across the span of the flow range.

Unique to the FCI ST80 Series is that the self-test may be initiated in three ways by the user:

- 1) On demand from the ST80 flow meter's keypad – through-the-glass activation, no need to remove the lid (Figure 1).
- 2) On demand from a computer connected to the flow meter's USB port.
- 3) Automatically on pre-set day(s) and time(s), programmable.

The results of the self-tests provide the operator with an easy to understand PASS/FAIL message for each of the three test points, plus the digital reading of the actual base line values shown in comparison to the actual resulting test values. The results are displayed on the ST80's digital display and/or the computer connected to the USB port.

Figure 1. Front panel; all three check points show "P" (pass) and entire self-check "PASSED"



For more rigorous "wet" in-situ calibration verification, see FCI Model ST110 with VeriCal™.

Digital Display / Readout and Keypad HMI Options

The ST80 is offered in three styles:

- No display
- With display, or
- With display and user interface buttons

The display is a best-in-class, backlighted information LCD. It provides users with both digital and bar graph readout of the processes flow rate and temperature, totalized flow, alarm trips, user defined label field,

and a fault indicator. The ST80 can be further enhanced by adding a four-button user interface. Exclusive to FCI, these buttons are finger-touch activated through the glass, without removing the lid. This means the ST80 can be changed, interrogated, and period diagnostic modes initiated without removing the instrument from the process, even in a hazardous area installation. Without the buttons, all programming and diagnostics must be performed via computer connection to the USB port.

Digital Display / Readout

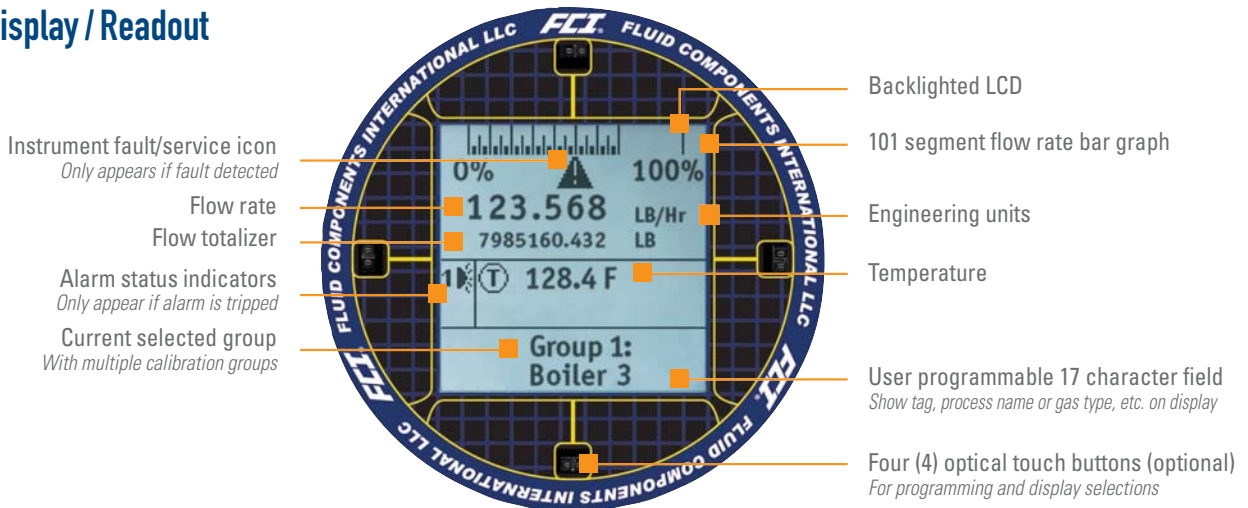

Full Instrument Agency Approvals

ST80 meters are agency approved for hazardous environment installations. FCI products undergo rigorous agency testing and obtain their approvals on the entire instrument, not just the enclosure. This highest level of agency certification is your evidence of FCI's integrity. This ensures that every FCI instrument meets the intended safety requirements of your installation.



FM, FMc: Explosion-Proof for Class I, Division 1, Groups B, C and D; Dust-Ignition-Proof for Class II/ III, Division 1, Groups E, F and G; Nonincendive for Class I, Division 2, Groups A, B, C and D; Nonincendive for Class II/III, Division 2, Groups E, F and G; indoor and outdoor Hazardous (Classified) Locations; Type 4X; IP66/IP67.

ATEX: II 2 G EX db IIC T6...T1 Gb Ta = - 40°C to + 60°C; IP66/67
II 2 D Ex tb IIIC T85°C...T450°C Db Ta = - 40°C to + 60°C; IP66/67 *

IECEx: Ex db IIC T6...T1 Gb Ta = - 40°C to + 60°C; IP66/67
Ex tb IIIC T85°C...T450°C Db Ta = - 40°C to + 60°C; IP66/67 *

Other Compliances: CE Marking, NEPSI, CPA, UKEX, UKCA, EAC/TR CU, CRN, EMSA EQM-Ex

Probe complies with NEC & CEC code requirements of ANSI/ISA 12.27.01-2011 as a single seal device

*Available in standard and elevated T-Ratings; see specifications on page 8.

FCI continually obtains additional agency approvals; contact FCI for availability of additional agency approvals

ST80 Series Features

Four conduit ports provide greatest signal integrity and separation for power input, analog output signals, and digital I/O; choice of NPT or M20 threads

SIL 1 Compliant

AC or DC power supply

Weather-proof, ruggedized, Ex rated enclosures

- Choices for local or remote mounting
- NEMA 4X, IP66/IP67
- Aluminum standard, stainless steel optional

Global agency approvals of entire instrument system for hazardous area installations:

FM, FMc, ATEX, IECEx, NEPSI, CPA, EAC (TRCU), UKEX, EMSA EQM-Ex

Precision calibration and calibration choices

- Up to two (2) calibrations
- Specific gas and application matched calibration using equipment traceable to NIST and ISO/IEC 17025

Extensive selection of process connections

- Simple, adjustable installation with threaded NPT connector
- Teflon or metal ferrule seals
- Fixed connections
- ANSI or DIN flanges
- Retractable assemblies

316L stainless steel or Hastelloy-C276 wetted parts

Precision, wide-ranging platinum RTD sensors

Choice of four flow element styles to optimize application performance

- FPC style
- FP style (*shown*)
- S style
- WG style (*wet gas*)

Extensive analog and digital communications output choices

- Dual 4-20 mA
- HART
- Modbus RS-485
- FOUNDATION Fieldbus H1
- PROFIBUS PA, PROFIBUS DP
- USB port

3-point user initiated calibration self-test

Optional four (4) optical touch buttons

- Proximity activation, no need to open enclosure
- Full instrument programmability
- Protected against unwanted activation

Optional comprehensive informational display

- Digital readout of all measured parameters; flow rate, total flow, temperature with engineering units
- Analog flow rate bar graph
- Alarm status indication
- Instrument fault indication
- User programmable 17 character field (*example: display gas type, tag number or application/location*)
- Display orientation rotates in 90° increments electronically
- Backlighted

Multi-function: measures mass flow rate and temperature

Permanent laser-etched depth gauge markings ensures accurate centering of adjustable-length elements

All-welded sensor elements for maximum service life and leak-proofing

Exclusive equal mass sensors provide optimum performance in processes with wide temperature swings



Remote up to 1000' [300 m]

Optional 316L stainless steel enclosure



ST80L in-line style

Optional sun shield



ST80 with sun shield

ST80 Series Mass Flow Meter Specifications

Instrument

- Measuring Capability**
 Flow rate, total flow and temperature
- Basic Style**
ST80: Insertion
ST80L: In-line (spool piece)
- Flow Measurement Range**
Insertion Style: 0.25 SFPS to 1000 SFPS [0,07 NMPS to 305 NMPS]
ST80L In-line: 0.0062 SCFM to 838 SCFM [0,01 NCMH to 1425 NCMH]
 – Air at standard conditions; 70 °F and 14.7 psia [21,1 °C and 1,01325 bar(a)]
- Temperature Measurement Range**
 Up to 850 °F [454 °C] commensurate with element; *see Operating Temperature in Flow Element specification*
- Media:** All gases that are compatible with the flow element material
- Accuracy**
Flow: Gas specific calibration: ± 1.0% reading, ± 0.5% full scale
Temperature: ± 2 °F [± 1,1 °C] (display only, flow rate must be greater than 5 AFPS [1,5 m/sec])
- Response Time (Flow)**
 1 second to 63% of final value (one step change) typical with –FP or –FPC type flow element operating in AST™ mode
- Temperature Coefficient**
With optional temperature compensation; valid from 10% to 100% of full scale calibration
Flow: Maximum ± 0.015% of reading / °F up to 850 °F [± 0.03% of reading / °C up to 454 °C]
- Repeatability**
Flow: ± 0.5% reading
Temperature: ± 1 °F [± 1 °C] (flow rate must be greater than 5 AFPS [1,5 NMPS])
- Turndown Ratio**
 Normally factory set and field adjustable from 2:1 to 100:1 within calibrated flow range
- Temperature Compensation**
Standard: ± 30 °F [± 16 °C]
Optional: ± 100 °F [± 55 °C]
- Agency Approvals**
 FM, FMC: Explosion-Proof for Class I, Division 1, Groups B, C and D;
 Dust-Ignition-Proof for Class II/ III, Division 1, Groups E, F and G;
 Nonincendive for Class I, Division 2, Groups A, B, C and D;
 Nonincendive for Class II/III, Division 2, Groups E, F and G;
 indoor and outdoor Hazardous (Classified) Locations;
 Type 4X; IP66/IP67.

 ATEX/UKEX: II 2 G Ex db IIC T6...T1 Gb Ta = - 40°C to + 60°C; IP66/67
 II 2 D Ex tb IIIC T85°C...T450°C Db Ta = - 40°C to + 60°C;
 IP66/67 *

 IECEx: Ex db IIC T6...T1 Gb Ta = - 40°C to + 60°C; IP66/67
 Ex tb IIIC T85°C...T450°C Db Ta = - 40°C to + 60°C;
 IP66/67 *

 Other CE Marking, NEPSI, CPA, EAC/TR CU, UKCA, EMSA EQM-Ex
 Compliances: Probe complies with NEC & CEC code requirements of ANSI/ISA 12.27.01-2011 as a single seal device. PED, RoHS

* T-Rating (Probes)	Process Temperature Range	
	Standard	Optional Elevated**
	Agency approval ordering Codes ATEX = Code 3 IECEX = Code 4	Agency approval ordering Codes ATEX = Code C IECEX = Code D
T4/T135 °C	- 40 °C to + 65 °C	- 40 °C to + 89 °C
T3/T200 °C	- 40 °C to + 115 °C	- 40 °C to + 154 °C
T2/T300 °C	- 40 °C to + 177 °C	- 40 °C to + 254 °C
T1/T450 °C	- 40 °C to + 365 °C	- 40 °C to + 404 °C

** Instrument will be fixed in AST™ measuring mode, and is not field-changeable into CP mode.

- SIL/IEC 61508:** SIL 1 Compliant, SFF 71.1% to 79.1%
- Calibration:** Performed on flow stands with equipment traceable to NIST and ISO/IEC 17025
- Other:** Follows best practices and guidelines as set forth in ISO 14511; complies with ISO 14164

Flow Element

- Material of Construction**
 All-welded 316L stainless steel; Hastelloy-C optional
- Operating Pressure**
ST80
 Metal ferrule: 1000 psig [70 bar (g)]
 Teflon ferrule: 150 psig [10 bar (g)] (200 °F [93 °C] maximum)
 Fixed connection NPT: 1000 psig [70 bar (g)]
 Fixed connection flanged: per flange rating
ST80L In-line style

	Tubing		Sch 40 Pipe		Sch 80 Pipe	
	Psig	Bar(g)	Psig	Bar(g)	Psig	Bar(g)
F Style Sensor						
1"	2400	165	2500	172	3000	207
1 1/2"			1750	121	2500*	172*
2"			1500	103	2250*	155*
S Style Sensor						
1"	2400	165	2500	172	2500	172
1 1/2"			1750	121	2500*	172*
2"			1500	103	2250*	155*

* 1 1/2" and 2" Sch 80 available by special order only; contact FCI
 3/4" pipe also available by special order

- Operating Temperature (Process)**
ST80
 -40 °F to 350 °F [-40 °C to 177 °C]
 -40 °F to 500 °F [-40 °C to 260 °C]
 -40 °F to 850 °F [-40 °C to 454 °C]
With Wet Gas (WG) sensor -40 °F to 350 °F [-40 °C to 177 °C]
ST80L In-line style
 -40 °F to 257 °F [-40 °C to 125 °C]

- Process Connection and Insertion Lengths – Model ST80**
Compression Fittings
 3/4" or 1" male NPT, stainless steel with adjustable Teflon ferrule or metal ferrule; or flanged tapped and threaded for 3/4" fitting, ANSI or DIN flanges
Compression fittings not available with 850 °F [454 °C] temperature versions of ST80

Retractable Packing Glands

Low pressure 50 psig [3,5 bar (g)] or medium pressure 500 psig [34 bar (g)] with graphite or Teflon packing material; 1 1/4" male NPT or ANSI or DIN flange
Teflon packing required when process media is ozone, chlorine or bromine; remote mount required when medium pressure packing gland is required

Fixed Fittings/All Welded

1" male NPT or ANSI or DIN flange

Insertion Length

Field adjustable lengths:

- 1" to 6" [25 mm to 152 mm]
- 1" to 12" [25 mm to 305 mm]
- 1" to 21" [25 mm to 533 mm]
- 1" to 36" [25 mm to 914 mm]
- 1" to 60" [25 mm to 1524 mm]

Fixed lengths from 2.6" to 60" [66 mm to 1524 mm]

■ In-line Flow Body and Process Connections – Model ST80L

Flow element is welded to an in-line flow tube, calibrated and supplied as a spool-piece; options include low flow injection tubes and built-in Vortab flow conditioners for optimum low flow rangeability and performance

Size: 1" diameter tubing; 1", 1 1/2" or 2" schedule 40 pipe;
1" schedule 80 pipe

Length: 9 nominal diameters

Process Connections: Female NPT, male NPT, ANSI or DIN flanges, or butt weld prepared

- **Remote Transmitter Configurations:** Transmitter may be mounted remotely from flow element using interconnecting cable (up to 1000' [300 m]); remote configuration required with selection of medium pressure packing gland

Flow Transmitter/Electronics

- **Operating Temperature:** -40 °F to 140 °F [-40 °C to 60 °C]

■ Input Power

AC: 85 Vac to 265 Vac, 50 Hz to 60 Hz; 10 watt

DC: 24 Vdc ± 20%; 9.6 watt

■ Outputs and Communications

Standard: Two (2) 4-20 mA³ analog, HART⁴, and Modbus RS-485⁴
4-20 mA outputs are user assignable to flow rate or temperature; outputs are user programmable to full flow range or subsets of full flow range

Standard: USB

Optional: FOUNDATION Fieldbus H1⁴, PROFIBUS PA⁴, or PROFIBUS DP⁴

³ 4-20 mA outputs are isolated and have fault indication per NAMUR NE43 guidelines, user selectable for high (> 21.0 mA) or low (< 3.6 mA)

⁴ Only one bus communication can be active at one time

■ Enclosures

Main Transmitter/Electronics

NEMA 4X, IP67; polyester powder coated aluminum or optional in 316L stainless steel; 4 conduit ports threaded as 1/2" NPT or M20x1.5; 7.74" x 5.40" x 5.00" [196,6 mm x 137,2 mm x 127 mm]

Local Enclosure (Remote Configuration):

Model ST80L, Model ST80 *without* packing gland option:

NEMA 4X, IP67; 2 conduit ports threaded as 1/2" NPT or M20x1.5; 3.75" x 4.00" x 3.24" [95 mm x 102 mm x 82 mm]

Model ST80 *with* packing gland option:

NEMA 4X, IP67; 1 conduit port threaded as 1" NPT or M20x1.5; 5.40" x 4.82" [137,2 mm x 122 mm]

■ Readout/Display (Option 1)

Specify Code J or K in order Block 11

- Large 2" x 2" [50 mm x 50 mm] LCD; digital plus bar graph and engineering units
- Digital displays of flow rate, total flow, and temperature; user selectable for engineering units
- Analog bar graph of flow rate
- Alarm status indication
- User programmable 17 alphanumeric character field associated with each calibration group
- Backlighted
- Display is electronically rotatable in 90° increments to optimize viewing angle

■ Readout/Display and Optical Touch Buttons (Option 2)

Specify Code F or H in order Block 11

Includes the *Readout/Display Option 1* items, plus adds four keypad/buttons for user interface

- Four (4) optical touch buttons
- User programming and set-up via the front panel
- Activation through the glass window – no need to open the enclosure to access or activate
- Set and adjust the meter or interrogate diagnostics in-situ, even in HazEx installation

Note: If display with buttons is not ordered, all user set-up and service interrogation must be done via computer link to bus comm and/or USB port

Other Options

■ Vortab Flow Conditioners

Available for all line size applications; standard choice with Model ST80L (in-line)

■ Sun Shield

Shades main transmitter, electronics and display from direct sunlight; 316L stainless steel

FCI PN 023241-01 *Integral transmitter*

FCI PN 023237-01 *Remote transmitter*

■ Ball Valves/Cable Glands

■ Certification and Testing Documentation

CMTR, NACE, PMI, O₂ cleaning, radiography, dye penetrant, hydrostatic or air pressure test, certificate of origin, certificate of conformance, wake frequency strength, and more

■ Field Service and Support

Start-up assistance, site commissioning and installation validation, maintenance agreements, bus communications integration and validation, and more

Specifications at reference operating conditions of 70 °F, 14.7 psia [21,1 °C, 1,013 bar(a)] and straight pipe run 20 d upstream, 10 d downstream

FCI is a continuous improvement company; specifications subject to change without notice

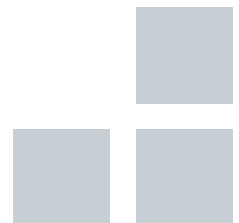

Model ST80 Single-Point Insertion Flow Meter INCH [MM]

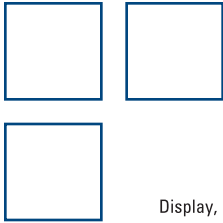

Integral Configuration

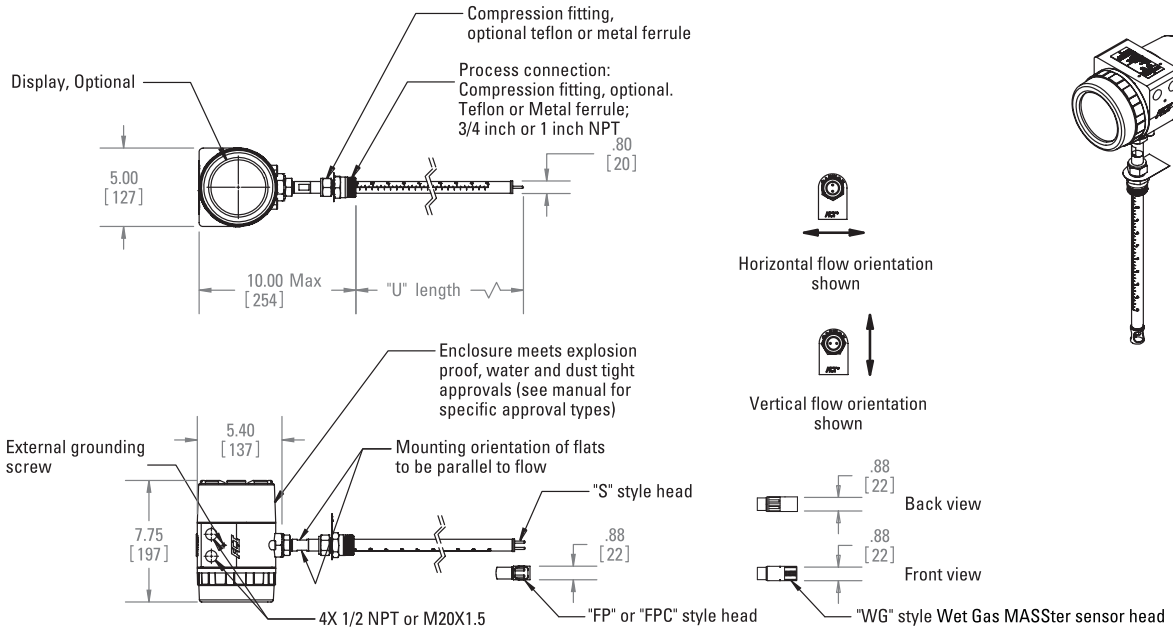

Remote Transmitter

With Ferrule Type Compression Fitting

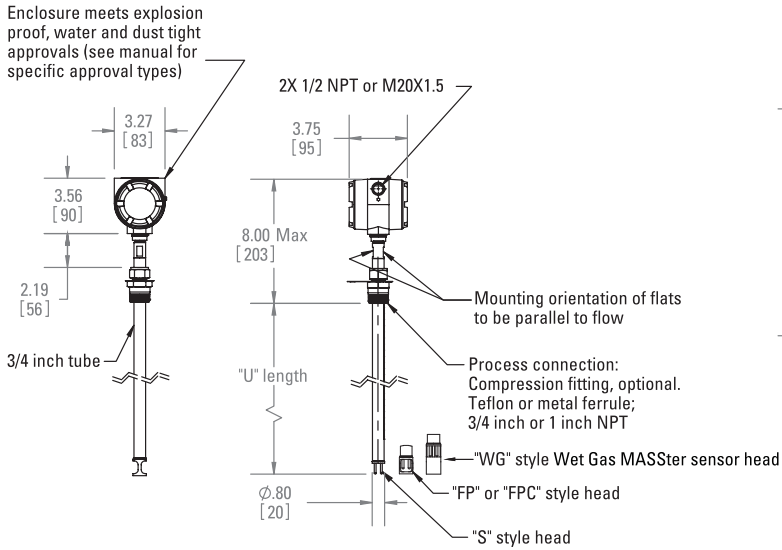

With Packing Gland

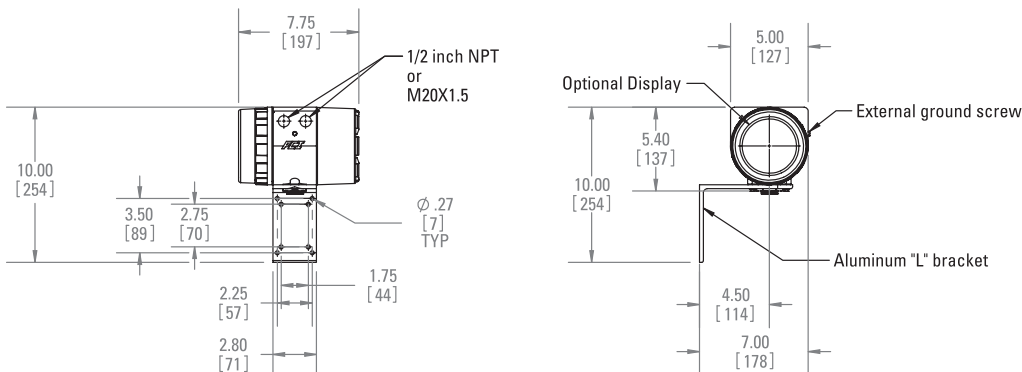
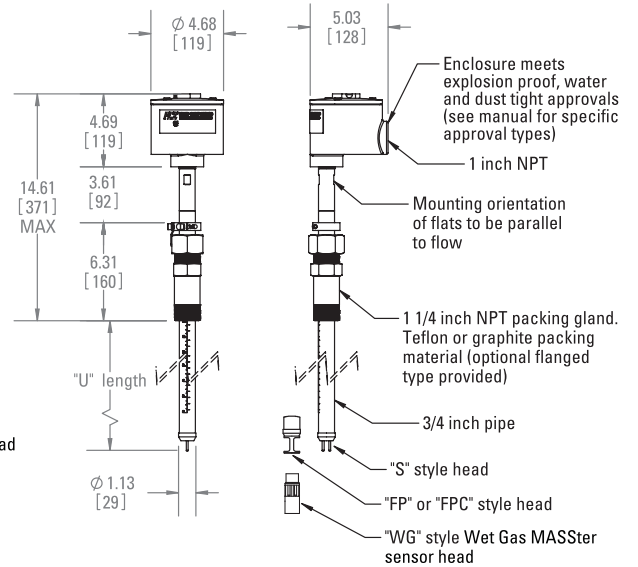

Model ST80L In-Line Flow Meter INCH [MM]

Integral Configuration

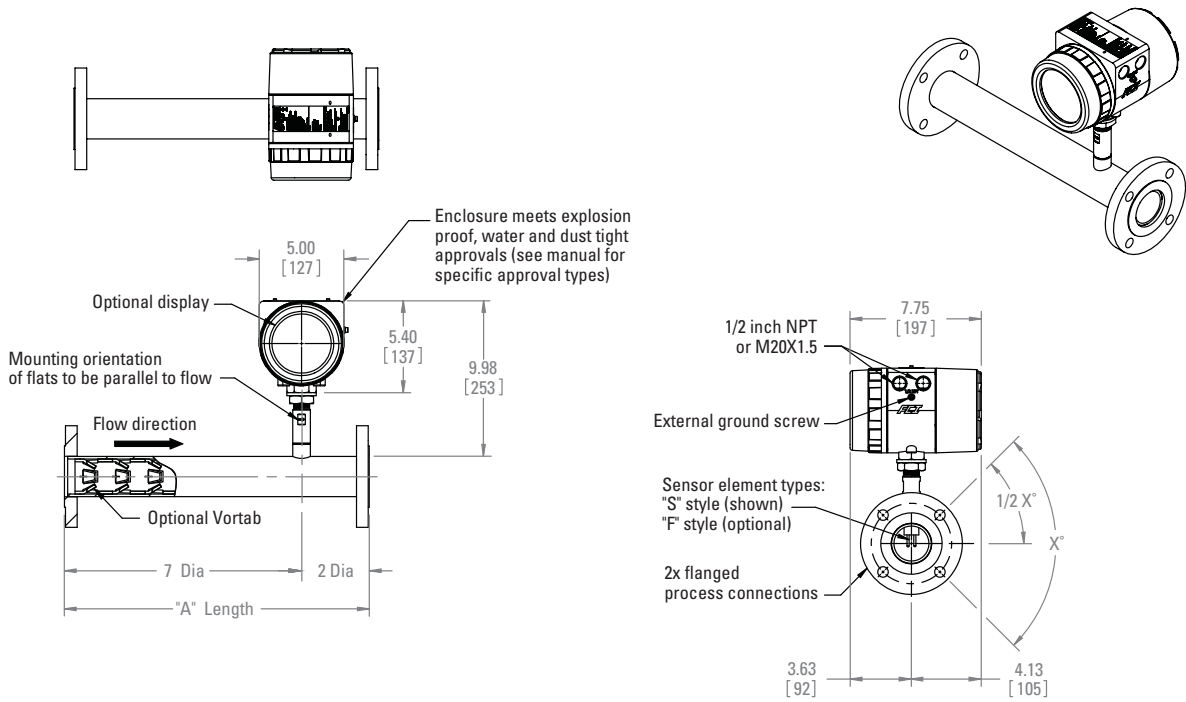

Remote Transmitter

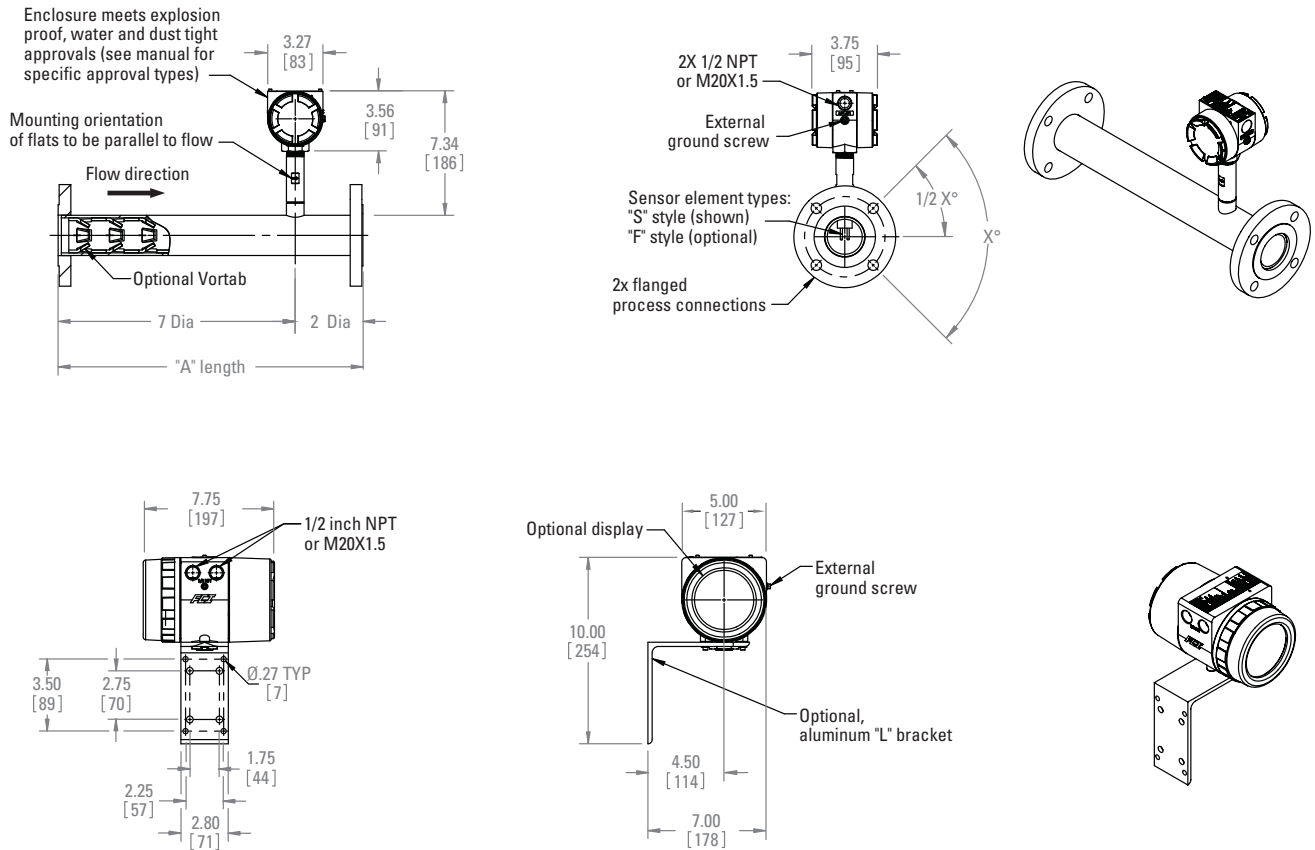

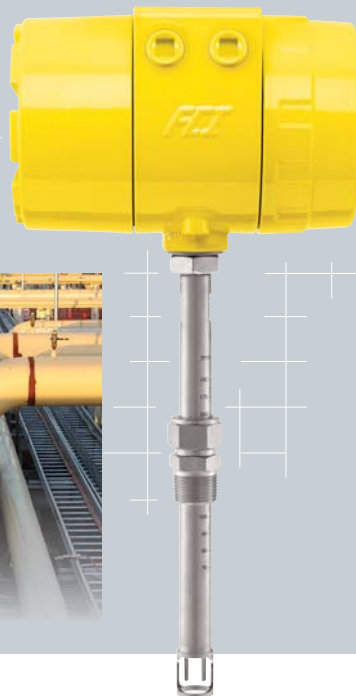
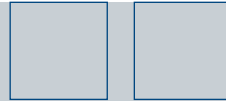
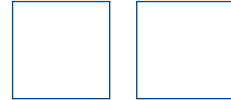
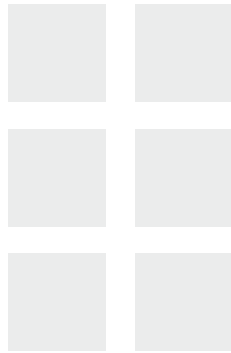

FCI FLUID COMPONENTS INTERNATIONAL LLC

A PST BRAND

Locally Represented By:

Visit FCI online at www.FluidComponents.com | FCI's Quality Management System is ISO 9001 and AS9100 Certified

FCI World Headquarters

1755 La Costa Meadows Drive | San Marcos, California 92078 USA

Phone: 760-744-6950 Toll Free (US): 800-854-1993

FCI Europe

Persephonestraat 3-01 | 5047 TT Tilburg, The Netherlands | Phone: 31-13-5159989

FCI Measurement and Control Technology (Beijing) Co., LTD

Room 107, Xianfeng Building II, No.7 Kaituo Road, Shangdi IT Industry Base, Haidian District | Beijing 100085, P. R. China

Phone: 86-10-82782381



1223

Copyright 2019-2024 by Fluid Components International LLC. All rights reserved. Manufactured in accordance with one or more of the following patents: US Patent Numbers 7,201,033; 8,806,955; 9,010,994 (CN, DE, GB, KR, NL); 9228881; 9528868; 9671265; 11,105,666 (CA, CN, DE, GB, KR); China Patent Number 2017800582146; and other US and foreign applications pending FCI and FCI design, FLT, Vortab, FCI Nuclear and FCI Nuclear design are registered trademarks of Fluid Components International LLC. Information subject to change without notice.

HART® is a registered trademark; Foundation™ Fieldbus is a trademark of FieldComm Group; PROFIBUS® is a registered trademark of PROFIBUS.

Doc. No. 02MK011542 E